

GENERAL INFORMATION---Descriptions to the control logic

The control-logic of TH-813 explained in the graphic descriptions.

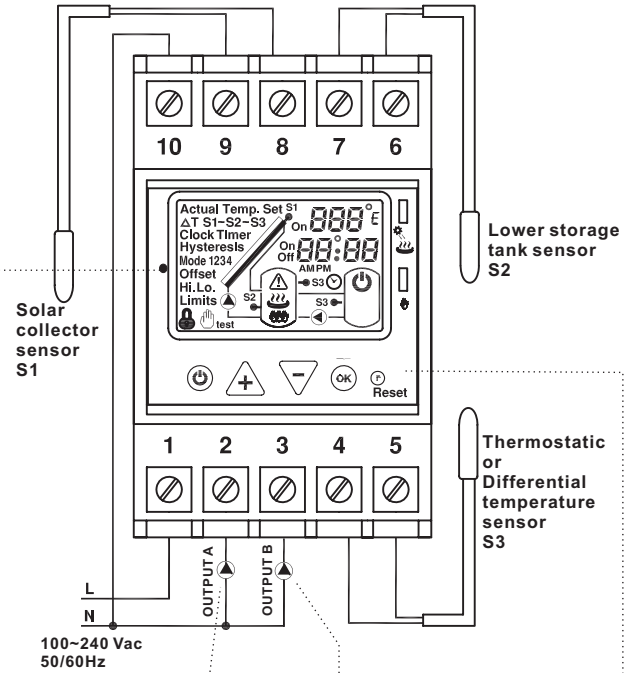
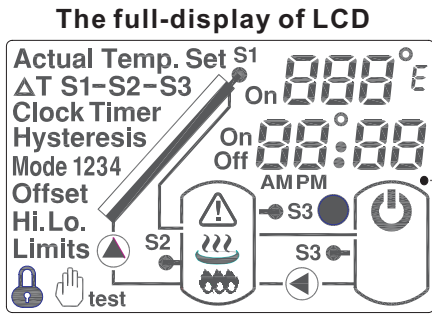

Turned on : Differential Temp.(S1-S2) > ΔT setpoint
 Turned off : Differential Temp.(S1-S2) < ΔT setpoint
 The same in all 4 modes

In Mode-2 and Mode-3
 Turned on : Temp. < setpoint in S3
 Turned off : Temp. > Setpoint in S3

in Mode-4
 Turned on : Differential Temp.(S2-S3) > ΔT setpoint
 Turned off : Differential Temp.(S2-S3) < ΔT setpoint

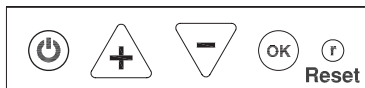
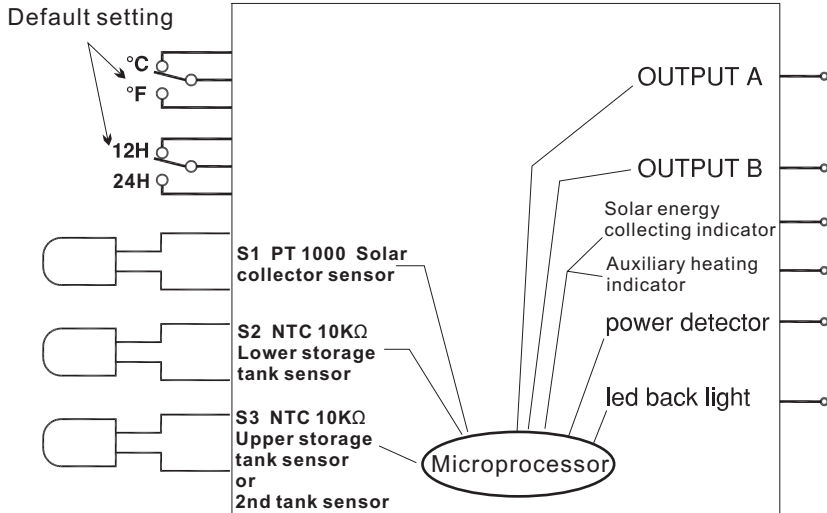

Parameter input buttons

GENERAL INFORMATION---Specification #1

S1- The solar collector temperature sensor

S2-The lower storage tank temperature sensor

S3-The upper storage tank sensor(Thermostatic or Differential sensor)

1. Operating voltage : 100 ~ 240 Vac 50/60 Hz
2. Output rating : (Solar collector circulation Pump) Output A – Volt output, 7 Amp \ 250 Vac
(Auxiliary heating) Output B – Volt output, 16 Amp \ 250 Vac
3. Power consumption : 4 VA
4. Clock format : 12H/24H by preset. Default setting 24H
5. °C/°F : By preset. Default setting °C
- (build-in **Protective functions**)
6. Anti-seizing protection : Automatic operation, the **Output A** will be turned on for 5 seconds everyday at midnight 12:00(00:00) when the night temperature is below 15°C.
7. Overheating protection : Automatic operation, when this protection is activated, backlight and  will be synchronous flashing on the LCD.

Overheating in the solar collector

In operating mode-1/2/3

Output A will be turned **on** when **S1** temperature \geq **S1** Hi temp.limits. setpoint
and **S2** temperature \leq **S2** (Hi temp.limits. Setpoint-2°C)

Output A will be turned **off** when **S1** temperature \leq (**S1** Hi temp. Limits. setpoint -5°C)
and **S2** \leq **S2** Hi temp.limits. Setpoint

In operating mode-4

Output A&B will be turned **on** when **S1** temperature \geq **S1** Hi temp. Limits setpoint
and **S2** temperature \leq (**S2** Hi temp. Limits Setpoint -2°C)

Output A&B will be turned **off** when **S1** temperature \leq (**S1** Hi temp. Limits. Setpoint -5°C)
and **S2** temperature \leq (**S2** Hi temp. Limits. Setpoint -2°C)

Overheating in the storage tank

In operating mode1/2/3

Output A will be turned **on** when **S2** temperature \geq **S2** Hi temp. limits Setpoint
and **S1** temperature \leq (**S1** Hi Temp. Limits. Setpoint -5°C)

Output A will be turned **off** when **S2** temperature \leq (**S2** Hi Temp. Limits. Setpoint -2°C)
and **S1** temperature \leq **S1** Hi Temp. Limits. Setpoint

In operating mode-4

Output A&B will be turned **on** when **S2** temperature \geq **S2** Hi temp. Limits. Setpoint
and **S1** temperature \leq (**S1** Hi Temp. Limits. Setpoint -5°C)

Output A&B will be turned **off** when **S2** temperature \leq (**S2** Hi Temp. Limits. Setpoint -2°C)
and **S1** temperature \leq **S1** Hi Temp. Limits. Setpoint

8. Anti-frost protection : Active when the unit is ON(in operation)
Output A Will be turned **on** for 1 minute in every hour when **S1** temperature =5°C
Output A will be permanent turned on when **S1** temperature=2°C, until **S1**>5°C
Enable(ON) or disable(OFF) this function is selectable. Default setting : OFF

(Set/adjust all the setpoints in the **S1,S2** and **S3**)

9. Set/adjust the “Hi. Temp. Limits.”(the overheating protection temperature setpoint) :
S1 : Setting range from 60°C to 190°C. Default setting 120°C
S2 : Setting range from 0°C to 100°C. Default setting 95°C
10. Set/adjust the “Lo Temp. Limits” (the lowest temperature protection setpoint) : Only in the **S1**
Output A will be shut off when temperature at **S1** is lower than “Lo Temp. Limits”
Setting range from 10°C to 40°C. Default setting 15°C
11. Δ T **S1-S2** : (Turn ON or OFF the solar collector circulation pump to the differential setpoints)
ON :The minimum required temperature difference between **S1 temperature at Solar panel** and **S2 temperature at the lower of storage tank** which is for turning ON Output A.
Setting range : 3 ~ 20 °C, default setting 10°C
OFF :The minimum required temperature difference between **S1 temperature at Solar panel** and **S2 temperature at the lower of storage tank** which is for turning OFF Output A to avoid reverse circulation. Setting range : 1 ~ 18 °C, default setting 3 °C

GENERAL INFORMATION---Specification #2

S1- The solar collector temperature sensor

S2-The lower storage tank temperature sensor

S3-The upper storage tank sensor(Thermostatic or Differential sensor)

12.ΔT S2-S3 : (Turn ON or OFF the Circulation pump to the differential setpoints) Effects in operating mode-4 only.

ON :The minimum required temperature difference between **S2 temperature at the lower of 1st storage tank** and **S3 temperature at the lower of 2nd storage tank** which is for turning ON Output B. Setting range : 3 ~ 20 °C, default setting 10°C

OFF :The minimum required temperature difference between **S2 temperature at the lower of 1st storage tank** and **S3 temperature at the lower of 2nd storage tank** which is turning OFF Output B. Setting range : 1 ~ 18 °C, default setting 3 °C

13.Set/adjust the temperature setpoints at **S2 & S3** and their Switching differential (Hysteresis) :

These setpoints will provide this unit with the thermostatic operation to automatically maintain the water in the storage tanks at the required temperature.

The setpoint at **S2** controls the ON/OFF in Output A.

The setpoint at **S3** controls the ON/OFF in Output B.

S2 : Setting range from 10°C to 100°C. Default setting 60°C

S2 : Switching differential : Setting range from 1°C to 20°C. Default setting 2°C

S3 : Setting range from 10°C to 100°C. Default setting 60°C

S3 : Switching differential : Setting range from 1°C to 20°C.

Default setting 10°C, in mode-2 and mode-3

Default setting 2°C, in mode-4

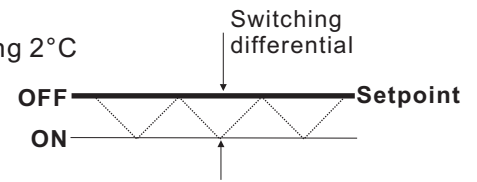

14. TIMER function : Active only in the operating mode -2 or 3, ON/OFF controls to the time setpoints in the Output B (**S3**). For solar collector systems with auxiliary heating.

Enable or **disable** this function is selectable. When the TIMER function is enabled, 2 ON-OFF(program-periods) /Day provided, program-resolution : 10 minutes. Default setting : **OFF**

15.Temperature sensor cable :

Collector sensor S1---PT1000, 1KΩ at 0°C, Temp. Coefficient $3.9 \times 10^{-3} / ^\circ\text{C}$. Resistance variable rate $0.3851 \Omega / ^\circ\text{C}$. Temperature display range $-40 \sim +250^\circ\text{C} / -40 \sim 482^\circ\text{F}$, Accuracy $\pm 0.5^\circ\text{C} / 1.0^\circ\text{F}$. Cable length : 2 meters, thermal-resistive PTFE shielding

Tank sensor S2---NTC, 10KΩ at 25°C.

Temperature display range $-10 \sim +110^\circ\text{C} / -14 \sim 230^\circ\text{F}$

Accuracy $\pm 0.5^\circ\text{C} / 1.0^\circ\text{F}$. Cable length : 2 meters, thermal-resistive PTFE shielding.

Tank sensor(thermostatic) S3---NTC, 10KΩ at 25°C. Temperature display range $-10 \sim +110^\circ\text{C} / -14 \sim 230^\circ\text{F}$.

Accuracy $\pm 0.5^\circ\text{C} / 1.0^\circ\text{F}$. Cable length : 2 meters, thermal-resistive PTFE shielding.

16.Temperature sensor's calibration : **Offset**(The same Offset range in all 3 sensors)

Range : $-10^\circ\text{C} \sim +10^\circ\text{C}$, default setting 0°C

17.Build-in Rechargeable battery for retaining the settings and the time during power outages

18.Stand-By mode  : Manually turn the unit ON/OFF (Output A & B can be turned-on/shut-off manually)

19.Key-lock function : Lock out of all the buttons on the front control-panel, prevents the settings from being tampered with.

20.Anti-Legionella function: **Effective only in S3. used for control the auxiliary heating.** (Control of Output B)

This function will operate manually only, when it is in operation, Output B will be turned on to heat up the water. When the water temperature reaches the setpoint, Output B will continue to operate for a duration of

(1080- (12x **Anti-legionella temperature setpoint**)) **Seconds.**

After, the unit will resume its normal operation.

Anti-legionella temperature setpoint: Setting range from 60°C to 90°C. Default setting 70°C

21.Blue backlit LCD, auto mode 10 seconds.

22.Dimensions : 52.5 W x 85.0 H x 60.0 D mm. 35 mm Din-rail

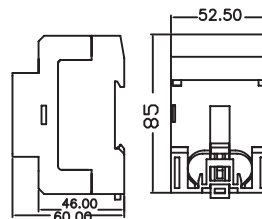

INSTALLATION---1.Content of the package

2.Wiring

3.Mount the unit on rail or wall



Disconnect power supply prior to starting installation & wiring the unit.

Content of the package

- Solar controller1
- Instruction sheet1
- Surface-mount bracket1
- Anchor $\Phi 9 \times 25$ L x 6 Dia. Mm 2
- Self-tapping screws $\Phi 7 \times 25$ L x 3.5 Dia. Mm ..2

The retractor on the back of the plastic housing is for clamping the unit on the Wall or Rail. Follow the graphic description below when mounting the unit.

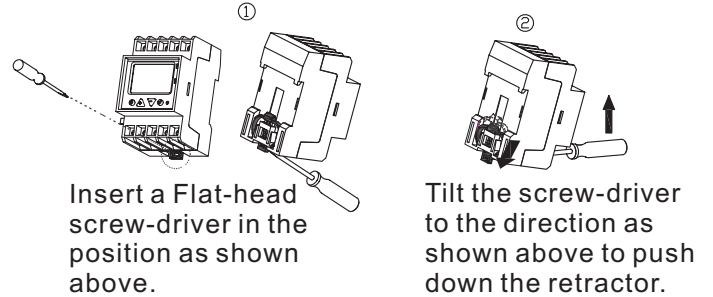

Remove battery insulation before wiring

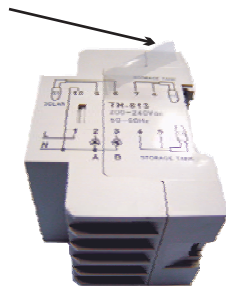

Mount/Remove the unit in surface-mount

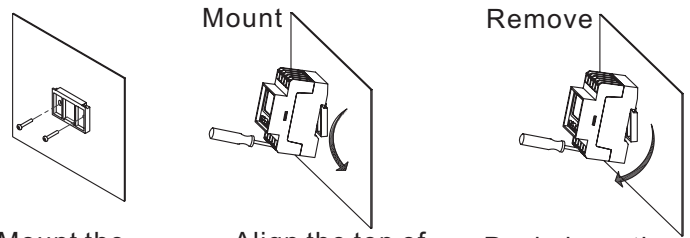

Mount the provided surface-mount-bracket on the wall.

Align the top of back plastic housing with the top of the bracket. Push down the retractor and mount.

Push down the retractor to remove the unit off the bracket.

Wiring

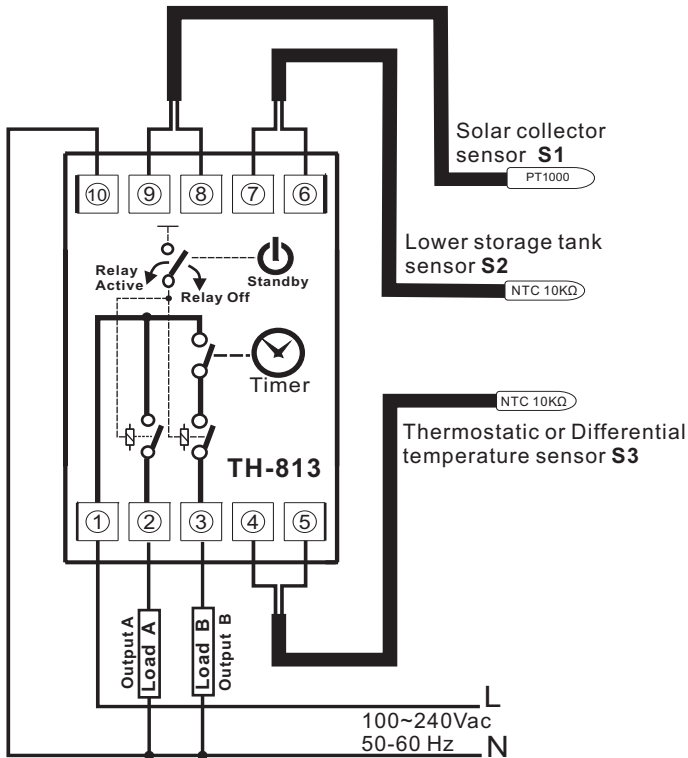

Mount/Remove the unit in din-rail mount

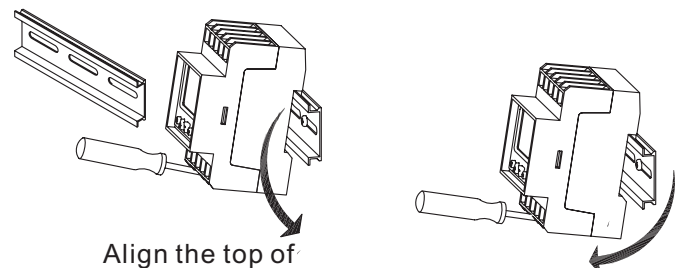

Align the top of the back plastic housing with the top of the Din-rail. Push down the retractor and mount.

Push down the retractor to remove the unit off the din-rail.

PROGRAMMING INSTRUCTION#1 ---1.Product descriptions

2.Set\Adjust internal settings-Part#1

Product description

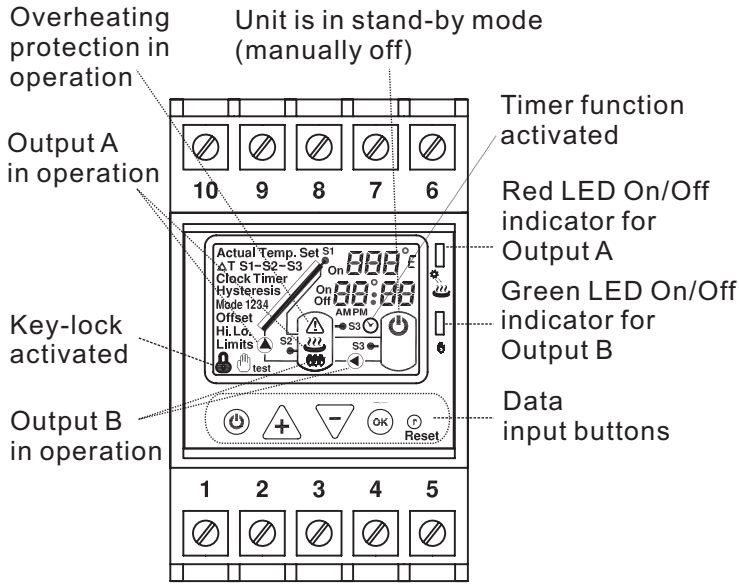

Set\Adjust internal settings

We suggest that you read the specification thoroughly before starting to set/adjust the unit.

This unit has preventive measures to avoid errors whilst in selecting the required operating mode.

When the error occurs, "Err" will be shown on LCD.

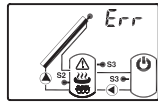

If this situation occurs, either press "reset" or press and together for 5 seconds to restart setting/adjusting.

Press "reset" prior to starting to set/adjust for first time use.

In the setting/adjusting procedure, if no data is input after 1 minute, this unit will automatic retain the settings and start to operate. Users may use this when just making adjustments in the internal settings.



Press and together for 5 seconds to start setting/adjusting

A.Set/Adjust the Clock

- 1.Press or to set the correct Hour of the day
- 2.Press to set the Minutes.
- 3.Press or to set the correct minutes.
- 4.Press to set/adjust next setting.

B.Anti-frost protection **A-F** (refer to the page of Specification Item-8 for a detailed description)

- 1.Press or to choose Enable (ON) or Disable(OFF) this function.

C.Set/Adjust the required operating mode

This unit provides 4 operating modes ,we suggest that you read the "Introduction" thoroughly in this Instructions before choosing.

- 1.Press or to choose the required mode.
- 2.Press to go to the next setting.

C-1 Hi Limits **S1** (Refer to the page of Specification Item-7 & 9 for a detailed description)

- 1.Press or to choose the required setpoint.
- 2.Press to go to the next setting.

C-2 Lo Limits **S1** (Refer to the page of Specification Item-10 for a detailed description)

- 1.Press or to choose the required setpoint.
- 2.Press to go to the next setting.

C-3 Hi Limits **S2** (Refer to the page of Specification Item-7 & 9 for a detailed description)

- 1.Press or to choose the required setpoint.
- 2.Press to go to the next setting.







D.ΔT **S1-S2 ON** and **OFF** setpoints (Refer to the page of Specification Item-11 for a detailed description)

- 1.Press or to choose the required **ON** setpoint.
- 2.Press to go to the next setting.
- 3.Press or to choose the required **OFF** setpoint.
- 4.Press to go to the next setting.

Next page

PROGRAMMING INSTRUCTION#2---2.Set\Adjust internal settings-Part#2







E. ΔT S2-S3 ON and OFF setpoints (Refer to the page of **Specification** Item-12 for a detailed description)

1. Press  or  to choose the required **ON** setpoint.
2. Press  to go to the next setting.
3. Press  or  to choose the required **OFF** setpoint.
4. Press  to go to the next setting.

(Effects in operating mode-4 only.)







F. Set/Adjust Operation setpoint and Hysteresis (Switching differential) in S2

(Thermostatic in Output A. Refer to the page of **Specification** Item-13 for a detailed description)

1. Press  or  to choose the required **S2** setpoint.
2. Press  to go to the Hysteresis setpoint.
3. Press  or  to choose the required **Hysteresis** setpoint.
4. Press  to go to the next setting.









G. Set/Adjust Operation setpoint and Hysteresis (Switching differential) in S3

(Thermostatic in Output B. Refer to the page of **Specification** Item-13 for a detailed description)

1. Press  or  to choose the required **S3** setpoint.
2. Press  to go to the Hysteresis setpoint.
3. Press  or  to choose the required **Hysteresis** setpoint.
4. Press  to go to the next setting.

(Effects in operating mode-2/ 3/ 4 only)

H. Offset – Temperature sensor’s calibration (Refer to the page of **Specification** Item-15/16 for a detailed description)

1. Press  or  to choose the required temperature calibration value in **S1**.
2. Press  for the calibration in **S2**.
3. Press  or  to choose the required value.
4. Press  for the calibration in **S3**.
5. Press  or  to choose the required value.
6. Press  to set the next setting













(Calibration in **S3** effects in operating mode-2 / 3 / 4 only)

I. Timer function (Refer to the page of **Introduction** and the page of **Specification** Item-14 for a detailed description, 2 program-periods are provided in this unit)

For setting the Timer,

press and hold  for fast forward

press and hold  for fast backward

1. Press  to enable the Timer function and to choose the required ON/OFF time in each program.
2. Press  or  to choose the time for **P1-ON**
3. Press  to set the **P1-OFF** time
4. Press  or  to choose.
5. Press  to set the **P2-ON** time.
6. Press  or  to choose.
7. Press  to set the **P-2 OFF** time.
8. Press  or  to choose.
9. Press  to go to the next setting

(Timer function activates in Mode-2 or 3 only)

All internal settings are now completed, press  to start operation.

OPERATION GUIDE (FOR USERS)



1. Stand-by mode (manually turn off this unit)
2. Anti-legionella function (Hygienic function)

When this unit is in operation, press

 or  to check the temperature

of each temperature sensor.

Stand-by mode

1. Press .
2. A Flashing "YES" will show on the LCD.
3. Press  again.
4. This unit is now manually turned off.

Remark:

When this unit was manually turned off, the build-in protective function will be automatically activated.

Refer to the page of **Specification** Item-6 Anti-seizing protection for the details.







When this unit is operating in stand-by mode, pressing the  button will resume its operation.

Anti-legionella function

This function activates only in systems equipped with auxiliary heating devices (mode-2 or 3).

Refer to the page of **Specification** Item-20 for a detailed description.

1. Press and hold  for 5 seconds.
2. Press  or  to set the required temperature setpoint for this Hygienic function.
3. Press  to start to operate this function

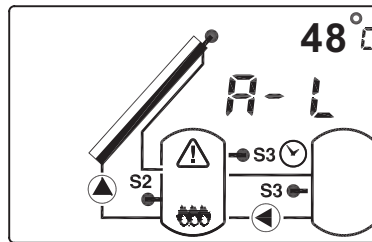

When this unit is operating the anti-legionella function, the LCD will show **A-L** and the S3 temperature.

Press  again will stop the operation.

This unit will automatic resume its normal operation after the anti-legionella function .

Remark:

Under two situations the backlight on the LCD will be flashing to alert users;

1. When this unit is in operating the overheating protection, it will display on the LCD;

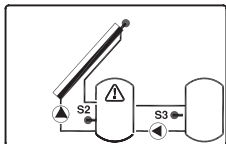

2. If any of the temperature sensor is not properly connected or has been damaged, it will display on the LCD;

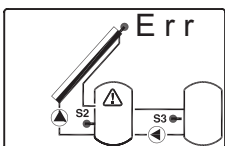



Also the symbol of  on the LCD will be synchronously in flashing.

Immediate contact service persons if this situation has occurred.

If the temperature at S3 could not reach the required A-L setpoint after this function has been in operation for one hour, the backlight will be flashing to alert users that the anti-legionella function has failed to operate.

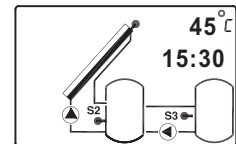
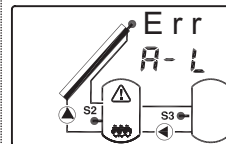
The display on the LCD will alternately show

















Press  to stop this **A-L** operation and immediately contact service personnel When this situation has occurred.

OPERATION GUIDE (FOR INSTALLERS)



1. Test mode
2. Resume default settings
3. Reset
4. Key-lock function

Test mode test

Check if both Output A and B are in good condition and ready to start operation. (In mode-1, Output A only)

1. Press and hold , then press .
2. Slow flashing Output A () will be shown on the LCD.
3. Press  to turn on Output A.
4. If Output A is in good condition, a fast flashing () will be shown on the LCD and the red LED  on the top right corner of panel will be turned on.
(Unit may be damaged if above situation did not occur)
5. Press  to turn off the test on Output A.
6. Press  to test Output B.
7. Slow flashing Output B ( or "S3" in mode-2) will be shown on the LCD.
8. Press  to turn on Output B.
9. If Output B is in good condition, a fast flashing () will be shown on the LCD and the green LED  on the top right corner of panel will be turned on.
(Unit may be damaged if above situation did not occur).
10. Press  to turn off the test on Output B.
11. After test, press and hold  and then press  to start operation.

Resume default settings

Press  and  together. "dEL" will be shown on the top right of the LCD.



All default settings will be resumed, the time will however be retained.

Reset





Press "Reset", the previous settings will be retained, however the time setting will be erased.

Key-lock function (Refer to the page of Specification Item-19 for a detailed description)

Press  and  together.  Will be shown on the bottom left of the LCD.

Any data input through the buttons on the panel is now invalid.

When the unit is in Key-lock mode, press

 and  together to release the Key-lock.